

| REVISIONS | | | |
|-----------|-----------------|------|----------|
| LTR | DESCRIPTION | DATE | APPROVED |
| — | INITIAL RELEASE | | H D |
| | | | |
| | | | |

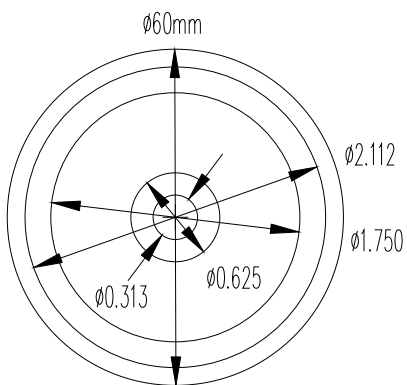
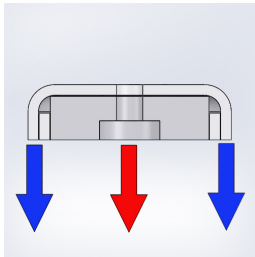
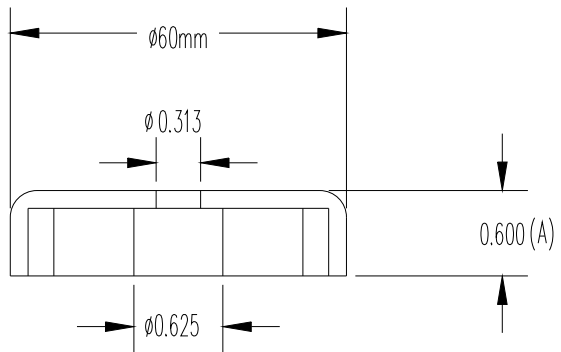
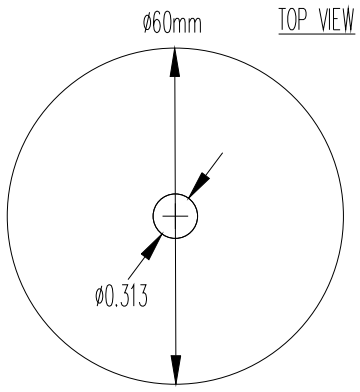

UNLESS OTHERWISE SPECIFIED
DIMENSIONS ARE IN INCHES

TOLERANCES:
FRACTIONS: ± 1/64
DECIMALS: ± 0.015
ANGLES: ± 1°

MATERIAL: NdFeB
FINISH: NiCuNi

| | | | |
|---|-----------|-------------|---|
| RADIAL MAGNETS INC. | | | |
| 108B NW 20th St. BOCA RATON, FL 33431 (561)392-2103 | | | |
| SHAPE | STRENGTH | PLATING | SIZE AND DIRECTION OF MAGNETIZATION (A) |
| POT | N35 | NiCuNi | POT B60 |
| SIZE | PART # | DRAWING # | REVISION |
| A | 8227 | RM8227 | - |
| SCALE 1 : 1 | DRAWN: CG | CHECKED: HD | APPROVED: HD |
| | | | PAGE 1 OF 1 |